

5.a Experiment: Resistors in Series and Parallel. Using the Digital Multimeter

At the beginning of the lab period, the instructor will show how to use a *digital multimeter*. See also the document “Using the Digital Multimeter”. **If you blow the fuse in your multimeter, you may not be able to complete this experiment.** For any experiment, *start by drawing the scheme by your hand, show by big dots the terminals locations for each circuit element and then build it on the desk by referring to your scheme.* Remember that there **must always be some resistance in series** with the **ammeter**. **NEVER CONNECT AN AMMETER IN PARALLEL WITH THE SOURCE**. If you are not sure about the connections, leave the switch open and have the circuit checked by instructor before you connect the source. In all cases, assume that relative uncertainty ($\mathcal{E}\%$) related to *scale reading* for current and voltage is **0.8%**. In this part of lab you will use the DC power supply as emf source.

- 1) Choose three resistors labelled **20, 30, 100 Ω** . For each resistor, build and use the circuit shown to measure the *potential difference across the resistor* (by a voltmeter 1.a) and the *current flowing through it* (by a multimeter 1.b). Use the recorded data to find the *true resistance* of each resistor. Report the results in a table to the appropriate number of significant figures and use these values in subsequent exercises.

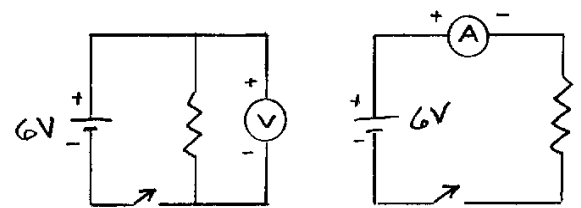

Figure 1a

Figure 1b

- 2) Connect the three resistors in series and measure the current through the set and the total potential difference across them as shown in fig.2 *If you have only the multimeter, use it first in the position of the voltmeter, then, turn the switch off, change the scale setting, connect it in the shown position as an ammeter and turn the switch on.* Show that the equivalent resistance of the combination,

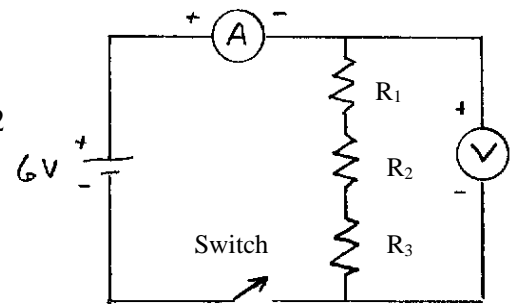

Figure 2

$R_{EQ} = V/I$ is equal to $R_{EQ} = R_1 + R_2 + R_3$

- 3) Connect the three resistors in parallel as shown and measure the potential difference across and the current through the combination. Show that the measured equivalent resistance of the combination, $R_{EQ} = V / I$ satisfies the relationship:

$$1/R_{EQ} = 1/R_1 + 1/R_2 + 1/R_3$$

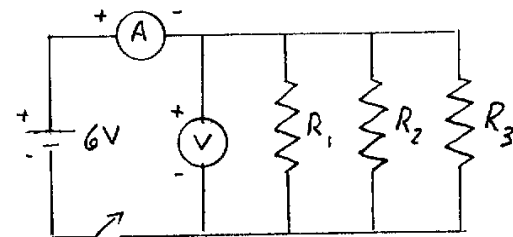

Figure 3

- 4) Use the circuit shown in fig. 4 to measure the internal resistance "*r*" for the *DC power supply* and for a **6 volt battery**. Note: When the switch is open, the voltmeter measures the ideal emf ($V_{op} = \mathcal{E}$). When the switch is closed, the voltmeter measures the terminal voltage $V_{ter} = RI = R \cdot \mathcal{E} / (r + R)$. Take two voltage readings, one with the switch open, the other with closed switch; use these two voltages to calculate "*r-value*" for the source (DC or battery).

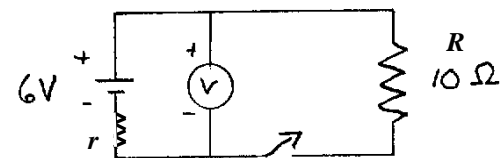

Figure 4

N.B. Do not leave the switch closed for more than a few seconds at a time; just long enough to obtain the readings.

5.b EXPERIMENT: Kirchoff's Rules

Objective: To verify Kirchoff's rules:

Loop Rule: The sum of all potential differences encountered while going around any closed loop in a circuit is zero:

$$\sum_i \Delta V_i = 0$$

N.B. There is a jump of potential (*positive difference* ΔV) when going from (-) to the (+) terminal of an *emf* and there is a drop of potential (*negative difference* ΔV) when going through a resistor *along the direction of current (as drawn)*. In the difference of potential $\Delta V = V_2 - V_1$, V_1 is the previous and V_2 is the last value while following the selected (*shown by drawing*) direction of circulation in circuit.

Junction Rule: The sum of all currents flowing into or out a junction in a circuit is zero:

$$\sum_i I_i = 0.$$

N.B. A current **flowing into the junction** is considered *positive* while the **current flowing out** of a circuit is considered *negative*.

Materials: Three resistors $R_1 = 20 \text{ Ohm}$, $R_2 = 30 \text{ Ohm}$, $R_3 = 100 \text{ Ohm}$, a voltmeter and an ammeter, two 6V batteries **in series** (or DC power supply) as \mathcal{E}_1 source and a 6V battery as \mathcal{E}_2 source.

Procedures: Before building the electric schemas, measure and record the precise resistance values by using the ohmmeter function of a multimeter (*if not done the measurements of part a*).

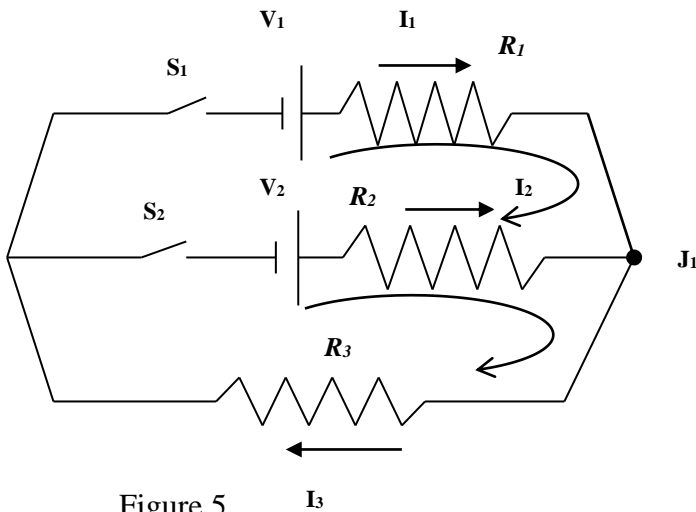

Figure 5

- Build carefully the circuit shown in figure 5.
- Choose a value $\mathcal{E}_1 = 10$ to 14V on first source.
- Turn on switches S_1, S_2 . **Measure** and **record** the terminal voltage V_1, V_2 of two sources by a voltmeter, and three current values I_1, I_2 and I_3 by using the DC ammeter function of multimeter. Connect the terminals of ammeter in conformity to the selected direction of current in diagram; record the **current with its sign**.
- Once finished with these measurements, switch off S_1 , and S_2 to avoid the discharge of batteries.
- Use the measured values V_1, V_2, I_1, I_2 and I_3 in the expressions (1,2,3); verify if they transform them to identities. Use the uncertainty intervals to prove this.

After selecting the circulation direction as shown in the figure the Kirchoff's rules give:

Loop _1(up): $V_1 - I_1 * R_1 + I_2 * R_2 - V_2 = 0 \rightarrow R_1 * I_1 - R_2 * I_2 = V_1 - V_2$ (1)

Loop _2(down): $V_2 - I_2 * R_2 - I_3 * R_3 = 0 \rightarrow R_2 * I_2 + R_3 * I_3 = V_2$ (2)

Junction _J1: $I_1 + I_2 - I_3 = 0 \rightarrow I_1 + I_2 = I_3$ (3)

Next, build the scheme presented in figure 6 by *inverting the poles of second source* \mathcal{E}_2 . Write three equations (1', 2', 3') derived from the Kirchoff's rules for the scheme in figure 6. Measure and record V_1, V_2, I_1, I_2 and I_3 . Repeat the procedure of verifications the same way you did for the scheme in figure 1.

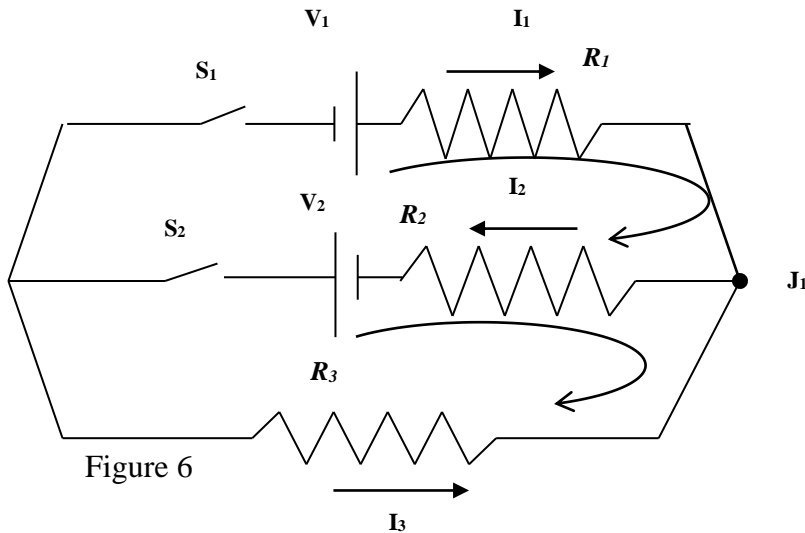

Calculations

- Put the measured values for terminal voltages V_1, V_2 , and resistors' values R_1, R_2, R_3 , in the equation (1', 2', 3') derived from Kirchoff's rules for the scheme in figure 6.
- Calculate the three current values I_{1c}, I_{2c} and I_{3c} from these equations.
- Compare the calculated values I_{1c}, I_{2c}, I_{3c} with the measured values I_1, I_2 and I_3 .

Conclusions:

- 1- Do your measured data satisfy the Kirchoff's rules at junction J_1 and around the two loops for the scheme in figure 5?
- 2- Do your theoretical calculations based on Kirchoff's rules fit with measured values for currents corresponding to the scheme in figure 6?